

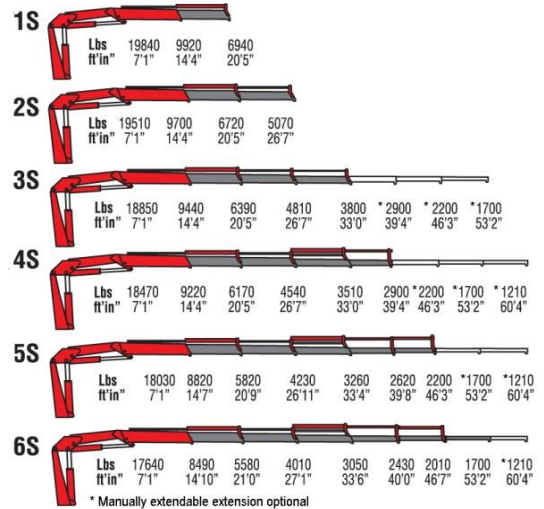

## Amco Veba 820 - 20 tm available with up to 6 hydraulic extensions



### REACH @ CAPACITY



SPECIFICATIONS	1S	2S	3S	4S	5S	6S
Number of Extensions	1-Hydraulic	2-Hydraulic	3-Hydraulic	4-Hydraulic	5-Hydraulic	6-Hydraulic
Crane Rating (ft. lbs.)	142,000	142,000	142,000	142,000	142,000	142,000
Max. Horizontal Reach - hydraulic	20'5"	26'7"	33'0"	39'4"	46'3"	53'2"
Max. Vertical Reach - hydraulic	32'6"	38'9"	45'3"	51'6"	58'4"	65'0"
Max. Capacity (lbs.)	6940	5070	3800	2900	2200	1700
Crane Weight (lbs.)	5030	5360	5670	5950	6170	6390
Crane Dimensions	98"x91"x39"	98"x91"x39"	98"x91"x40"	98"x91"x40"	98"x91"x40"	99"x91"x40"
Mounting Space	8'2"x3'3"x7'6"	8'2"x3'3"x7'6"	8'2"x3'3"x7'6"	8'2"x3'3"x7'6"	8'2"x3'3"x7'6"	8'2"x3'3"x7'6"
Slewing Angle (degrees)	387	387	387	387	387	387
Oil Tank Capacity (gallons)	34.3	34.3	34.3	34.3	34.3	34.3
Max. Oil Flow (gpm)	10.6	10.6	10.6	10.6	10.6	10.6
Max. Working Pressure (psi)	4531	4531	4531	4531	4531	4531
Outrigger Extension	18'1"	18'1"	18'1"	18'1"	18'1"	18'1"

### STANDARD FEATURES

- Dual side controls - except with remote
- Hexagonal extension cylinders
- Sliding pads on telescopic extensions
- Flanged Valves
- Self lubricating bushings
- Oil tank
- Din and JIC fittings
- Designed in accordance with EN 12999
- Fatigue test classifications: B3
- Rack and pinion rotation
- Manually extendable stabilizers
- One year warranty

### ACCESSORIES

- RRS radio remote
- Manual extensions
- Optional load limiting device
- Extra function to boom tip
- Extra valve function for winch
- Winch
- Pressure gauge
- Gear pump
- Winch plate
- Turning stabilizers
- Extra side extension of stabilizers
- Stabilizers with hydraulic extensions

# DIMENSIONS

## 820-823 6S

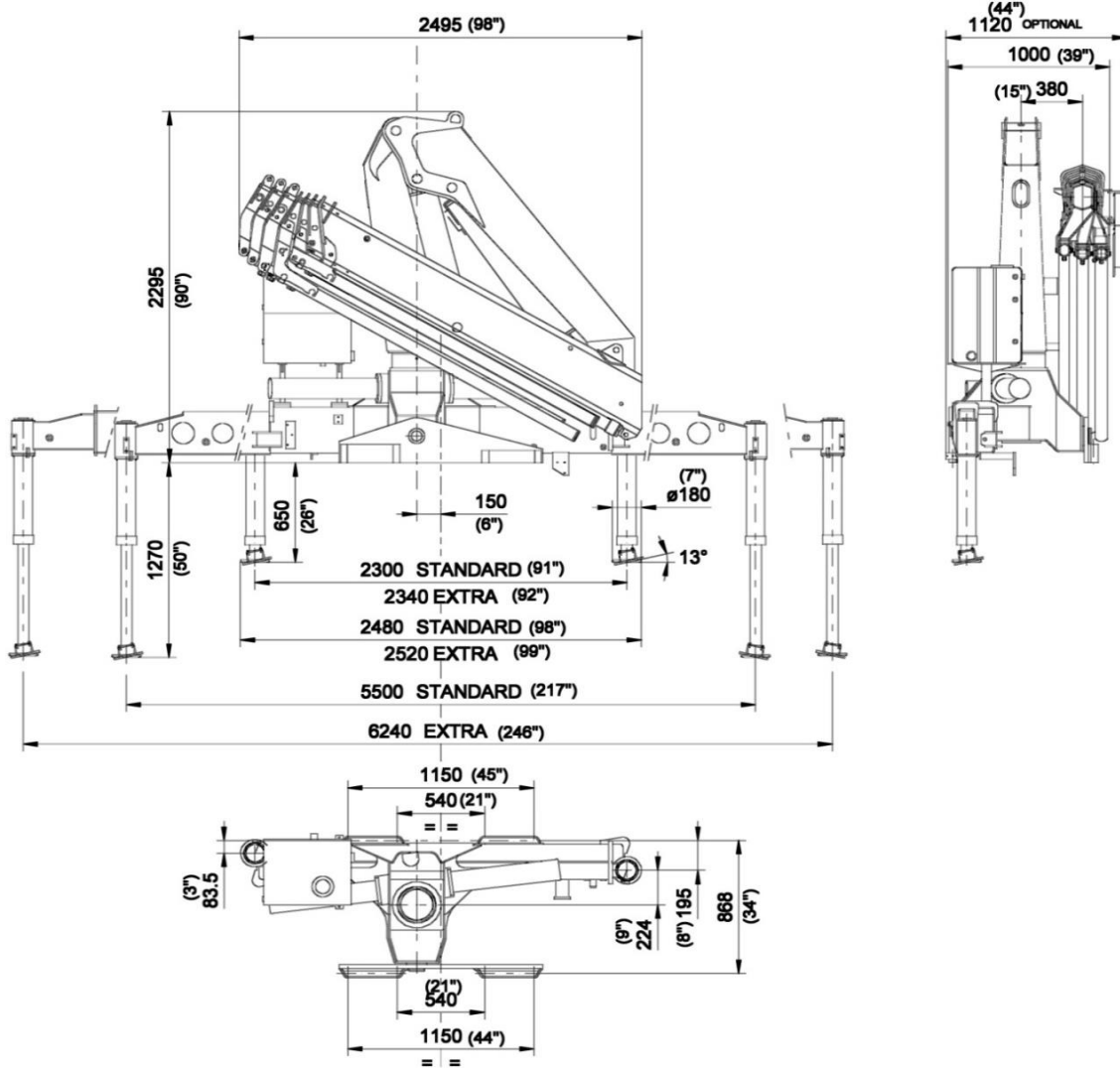

Rev. 2014-02

7 / 43

# SPECIAL FEATURES



## SDD Soft Descend Drive

The SDD system is designed to reduce the oscillations and ensure a perfect control of the motions



## SGS Sprint Generation System

The purpose of SGS system is to increase the extensions speed without affecting the crane safety.



## AVPS Amco Veba Power System

AVPS system can reach longer outreach with very heavy load, with the highest precision.

*\*Optional Radio Remote Control*

*\*Only with CE or Radio Remote Control*



## RRS Radio Remote Control

The operator can control the crane with high precision proportional levers in every position, and in doing so, can supervise the loading and unloading operations. That means a time savings and greater safety. The operator can also control the truck engine start, stop and accelerator with the remote control. All of the remote controls used by AMCO VEBA have an identification code and are shielded from electro-magnetic fields and from external radio signals.



## EBB Electronic Black Box

Amco Veba has designed this control motherboard to ensure an effective and reliable control of the crane in every working condition. The operator can read on the display all the information about the state of the crane, of the accessories, and of the routine maintenance. All components are designed according to automotive industry standards and ensure the highest reliability.